

# F504 VELO 115/230V

## PARTS LIST

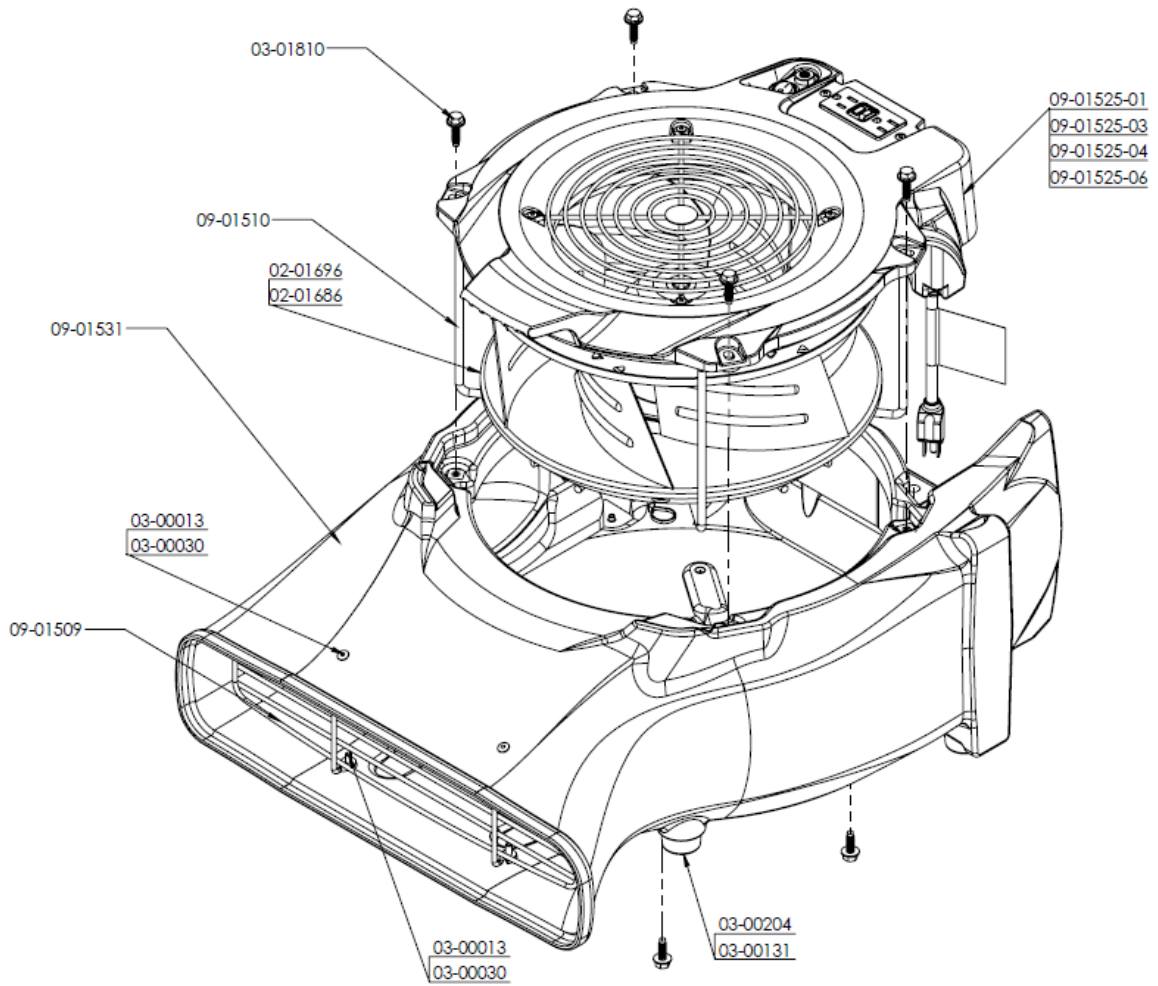

**CONTINUES ON NEXT PAGE**

<b>PART NO.</b>	<b>QTY</b>	<b>DESCRIPTION</b>
02-01686	1	BLOWER ASSY - MOTORIZED IMPELLER 115V 190W 1600 RPM 1SP VELO
02-01696	1	BLOWER ASSY - MOTORIZED IMPELLER 230V 124W 1300 RPM 1SP VELO
03-00013	4	WASHER - 3/16 RIVET .19 ID X .47 OD X .05 ZP
03-00030	4	RIVET - 3/16 X 1/2 AL/AL BLK ANOD
03-00131	4	FOOT - ROUND 3/16 ID X 1.25 OD X 5/8 RUBBER BLK
03-00204	4	RIVET - 3/16 X 5/8 TRI FOLD AL/AL
03-01810	4	SCREW - M6 X 22MM HWH NYLOC ZP MATPOINT
09-01509	1	GRILL - OUTLET PC GL BLK VELO
09-01510	1	MOUNT - BLOWER WIRE FORM ZP STL VELO
09-01525-01	1	ELECTRICAL BOX ASSY - 115V VELO
09-01525-03	1	ELECTRICAL BOX ASSY - 230V VELO EU
09-01525-04	1	ELECTRICAL BOX ASSY - 230V VELO AU
09-01525-06	1	ELECTRICAL BOX ASSY - 230V VELO UK
09-01531	1	HOUSING - POLYETHYLENE VELO FISHER BLUE

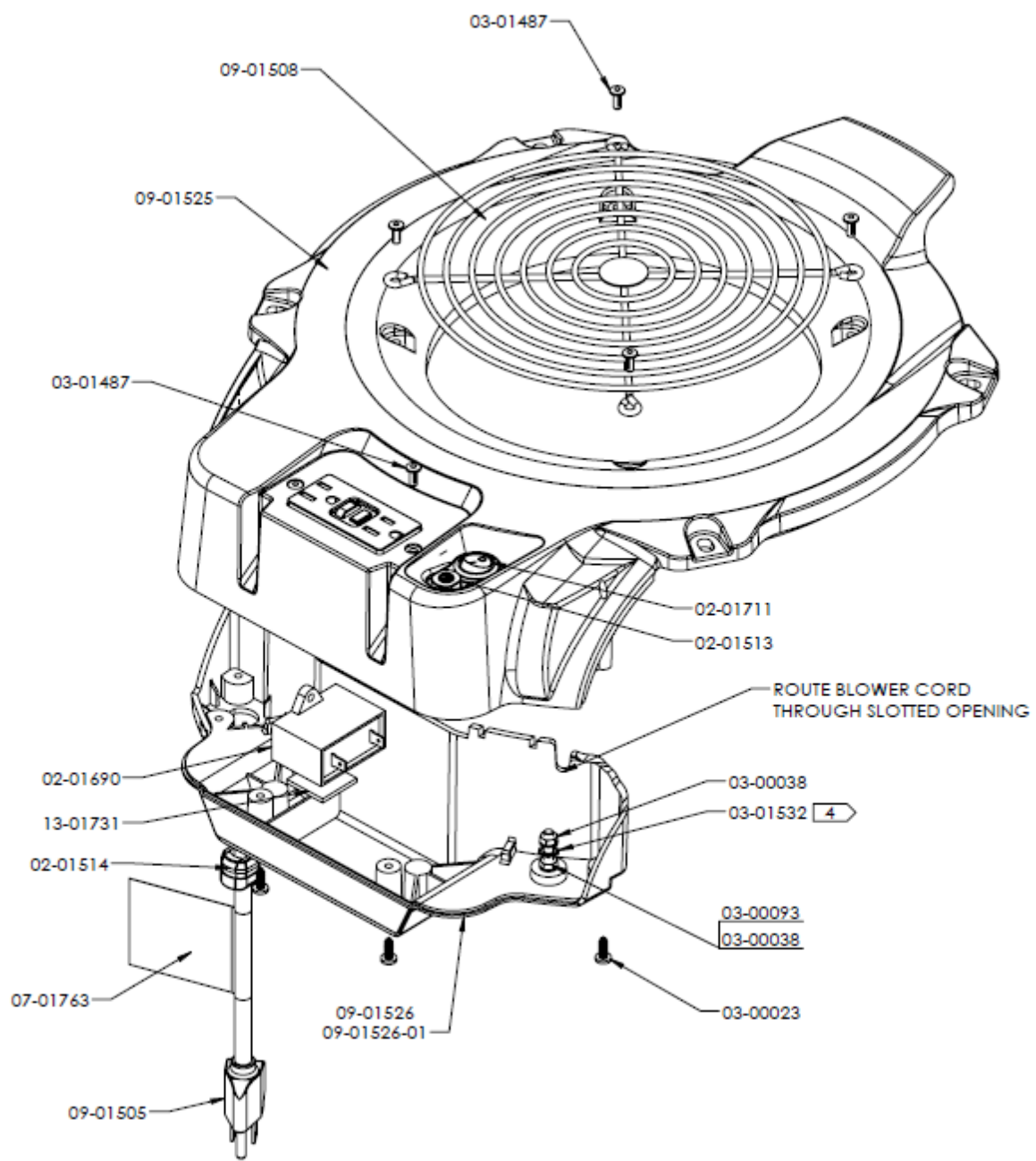

115V

<b>PART NO.</b>	<b>QTY</b>	<b>DESCRIPTION</b>
02-01513	1	CIRCUIT BREAKER – 12A THERMAL SNAP
02-01514	1	STRAIN RELIEF – LIQUID TIGHT .370 DIA X .13 BLK
02-01690	1	CAPACITOR – 16MFD 250V W/MTG BRKT
02-01711	1	SWITCH – ROCKER SPST ROUND
03-00023	5	SCREW - #8 X ½ PHIL PH ZP
03-00038	2	NUT - #10-24 W/STAR WASHER ZP
03-00093	1	SCREW - #10-24 X 1 SER HWH ZP
03-01487	6	RIVET – 5/32 X ¼ TRI FOLD AL/AL BLK
07-01763	1	LABEL – WARNING POWER CORD FANS
09-01505	1	POWER CORD ASSY – 14/3 SJTW 5015P 15FT VELO
09-01508	1	GRILL – INLET PC GL BLK VELO
09-01526	1	PANEL – ELECTRICAL BOX BOTTOM ABS BLK VELO
09-01529	1	ENCLOSURE – ELECTRICAL BOX INLET RING 115V VELO
13-01731	1	TAPE – 1 IN WIDE DOUBLE SIDED MTG HEAVY DUTY

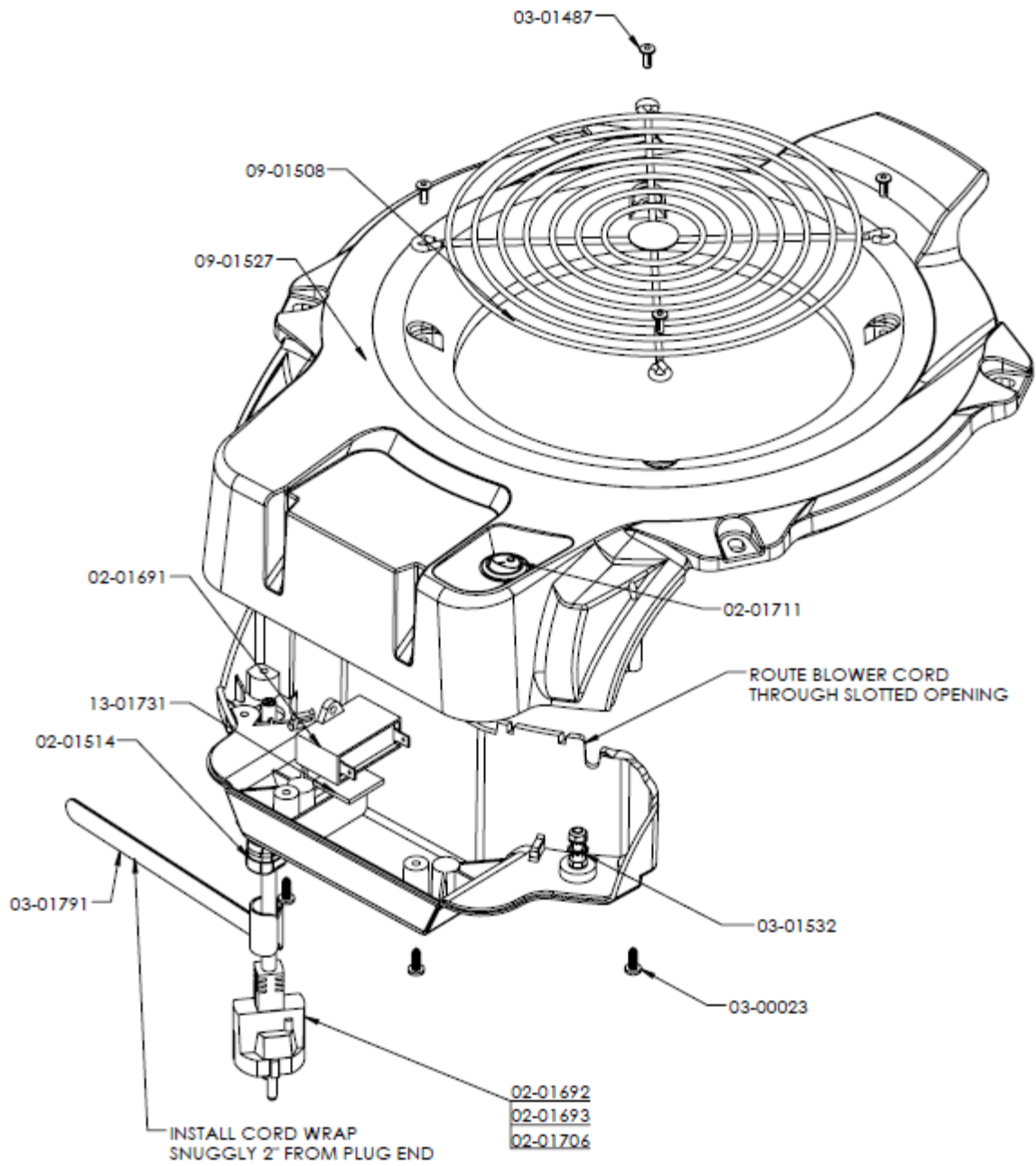

<b>PART NO.</b>	<b>QTY</b>	<b>DESCRIPTION</b>
02-01514	1	STRAIN RELIEF – LIQUID TIGHT .370 DIA X .13 BLK
02-01691	1	CAPACITOR – 16MFD 250V W/MTG BRKT
02-01692	1	POWER CORD ASSY – 3 X 1.0MM HO7RNF CEE7/7 16FT VELO
02-01693	1	POWER CORD ASSY – 3 X 1.00MM HO7RNF AS 3112
02-01706	1	POWER CORD ASSY – 3 X 1.0MM HO7RNF BS1363 16FT VELO
02-01711	1	SWITCH – ROCKER SPST ROUND
03-00023	5	SCREW - #8 X ½ PHIL PH ZP
03-01487	4	RIVET – 5/32 X ¼ TRI FOLD AL/AL BLK
03-01532	2	WASHER - #10 ANSI EXTERNAL TOOTH ZP
03-01791	1	STRAP – VELCRO CABLE TIE 8.00 X .50
09-01508	1	GRILL – INLET PC GL BLK VELO
09-01527	1	ENCLOSURE – ELECTRICAL BOX INLET RING 230V VELO
13-01731	1	TAPE – 1 IN WIDE DOUBLE SIDED MTG HEAVY DUTY

© VELO - 115V 60HZ WIRING DIAGRAM

VELO - 230V 50HZ WIRING DIAGRAM

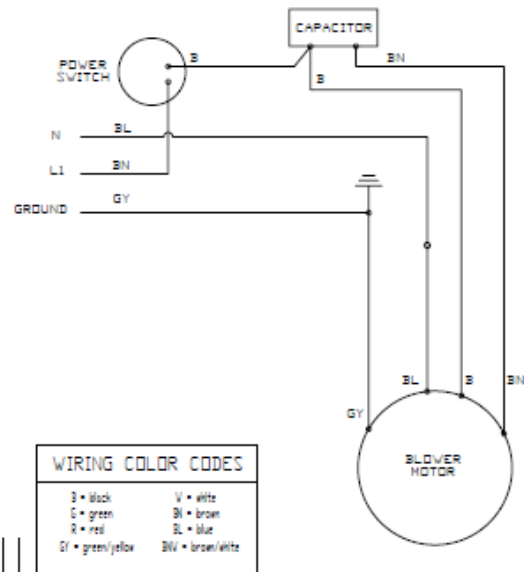
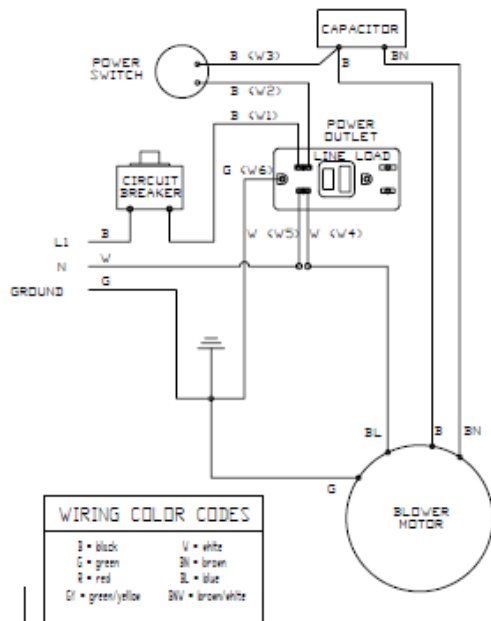

## INSIDE VIEW

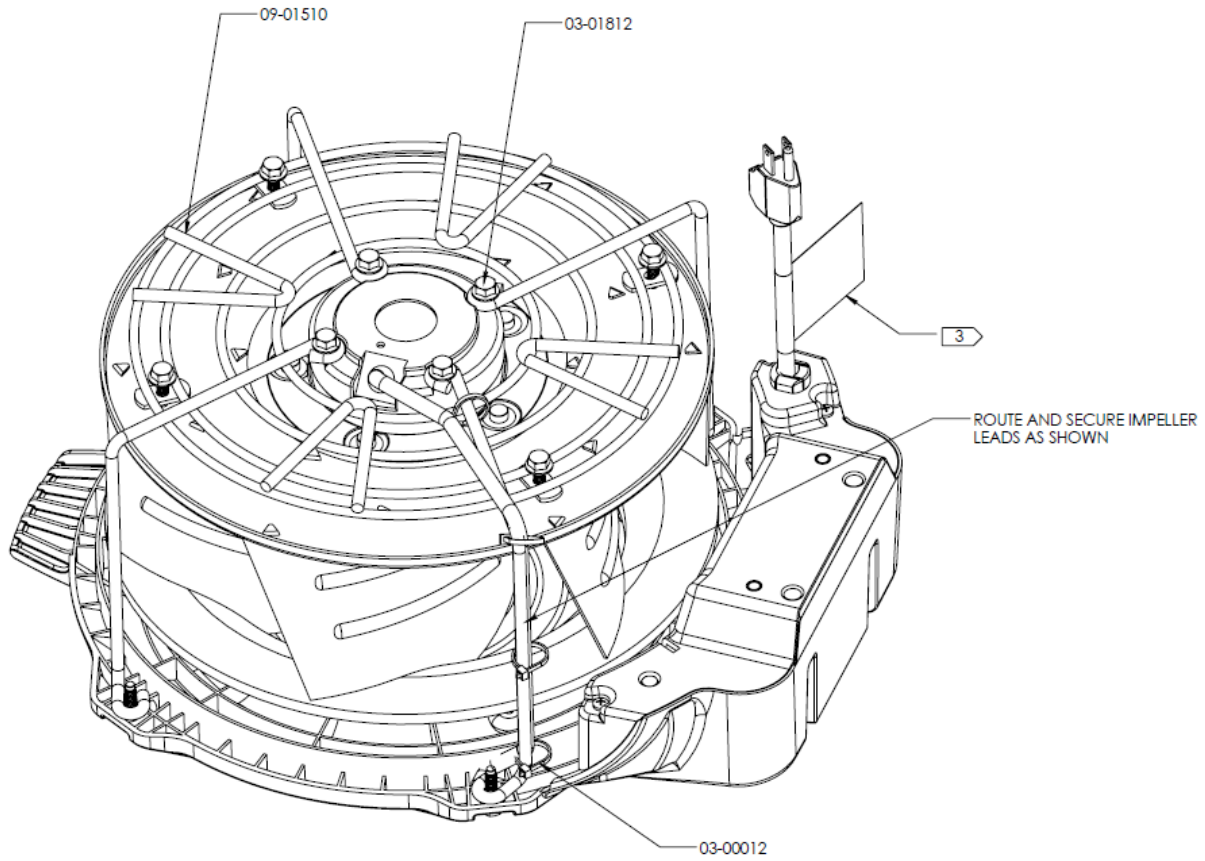

<b>PART NO.</b>	<b>QTY</b>	<b>DESCRIPTION</b>
03-00012	4	CABLE TIE - 4 NYLON
03-01812	8	SCREW - M6 X 18MM HWH NYLOC ZP MATPOINT
09-01510	1	MOUNT - BLOWER WIRE FORM ZP STL VELO

**BOTTOM VIEW**

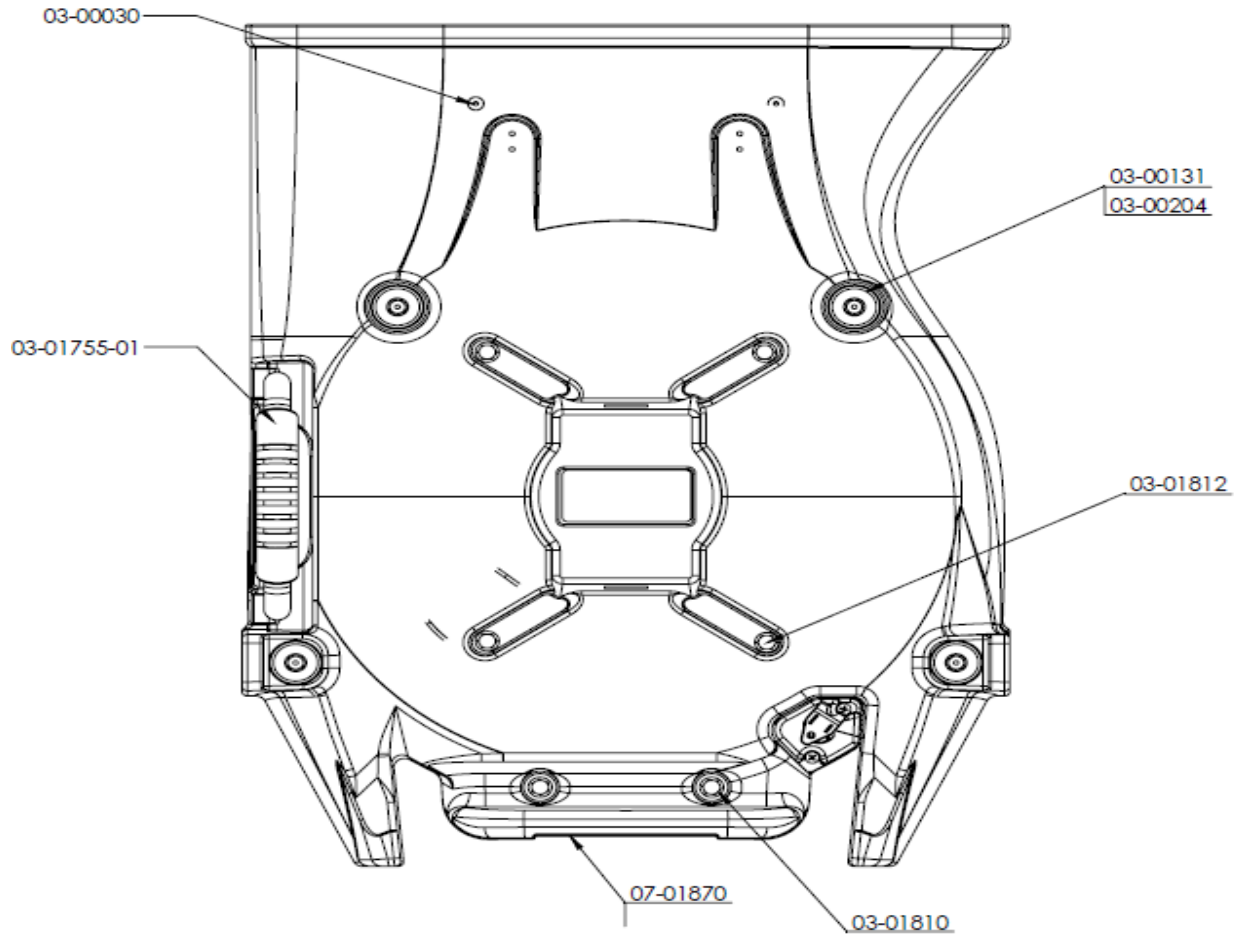

<b>PART NO.</b>	<b>QTY</b>	<b>DESCRIPTION</b>
03-00030	4	RIVET - 3/16 X 1/2 AL/AL BLK ANOD
03-00131	4	FOOT - ROUND 3/16 ID X 1.25 OD X 5/8 RUBBER BLK
03-00204	4	RIVET - 3/16 X 5/8 TRI FOLD AL/AL
03-01755-01	1	HANDLE - GRAB WITH LIFTING STRAP
03-01810	2	SCREW - M6 X 22MM HWH NYLOC ZP MATPOINT
03-01812	4	SCREW - M6 X 18MM HWH NYLOC ZP MATPOINT
07-01870	1	LABEL - WARNING VELO
07-01896	1	LABEL - WARNING HEYLO



### **HANDLE VIEW**

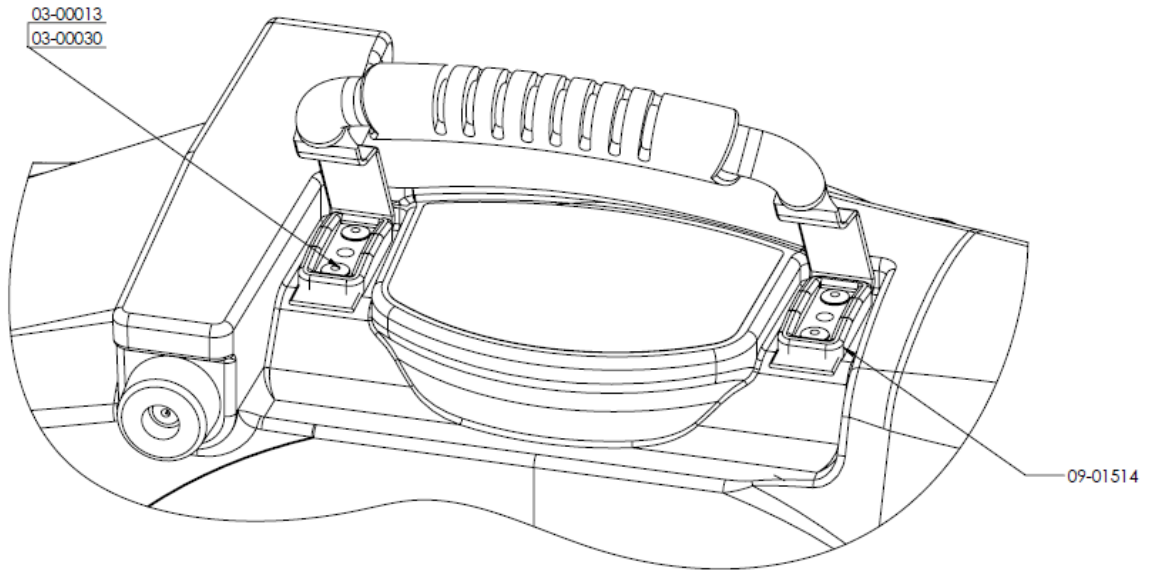

<b>PART NO.</b>	<b>QTY</b>	<b>DESCRIPTION</b>
03-00013	4	WASHER - 3/16 RIVET .19 ID X .47 OD X .05 ZP
03-00030	4	RIVET - 3/16 X 1/2 AL/AL BLK ANOD
09-01514	2	CLIP - HANDLE MTG NYLON BLK

**SIDE VIEW (LABEL)**

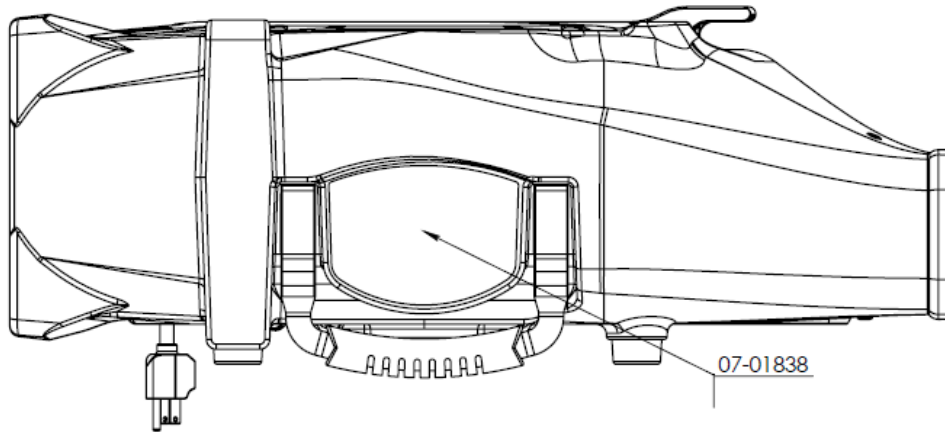

<b>PART NO.</b>	<b>QTY</b>	<b>DESCRIPTION</b>
07-01838	1	LABEL - PRODUCT VELO